



TASK SUPPORT VEHICLE

CAPACITY: 1,000 lbs.

MV05

SERIES 8906

Capacity

- 1,000 lbs. total vehicle capacity up to 126" elevation
- 300 lbs. operators compartment
- 500 lbs. front work platform
- 200 lbs. rear hideaway tray

Weight

- 2,268 lbs. to 3,160 lbs. chassis only

Wheels / Tires

- Drive: (1)9" x 3" polyurethane
- Stability: (2)3" x 2" polyurethane
- Load: (2)8" x 3" polyurethane

Battery Compartments

- MV05-126 & J1-162: 29.1" x 7.9" x open
- MV05-192: 29.1" x 11" x open



Standard Equipment

- Electronic power steering
- Hideaway rear work tray
- Front and rear flashing light
- Battery compartment rollers

Optional Equipment

- Anchor with tether and harness
- High-speed travel
- Tow hitch (2,500 lbs. tow capacity)
- Industrial battery with external charger
- 224AH AGM battery pack with 120V charger
- 12V power outlet adapter

Speeds

- 24V ZAPI AC-0 travel controller
- 4 operator-selectable travel settings and turtle speed mode
- Standard travel speeds from 0 to 3.4 mph
- High speed option available
- Ground level travel of up to 5 mph
- Lift speed up to 42 fpm

Electrical

- 24V AC system manages the vehicles electronic power steering, acceleration, neutral braking and automatic speed reduction at height and during tight turns when cornering
- AC drive motor provides high torque throughout the entire drive range
- Brushless design of AC technology drastically reduces maintenance and extends battery range
- Lift and lower controls are single speed
- Zapi LCD dashboard display includes fault code diagnostics, hour meter, battery state of charge, travel speed and drive wheel directional indicator
- Emergency power disconnect, key switch and horn as standard equipment

Mast

- Heavy duty I-beam design for excellent stability at height
- Steel mast channels and side mounted lift cylinders increases platform capacity

Chassis

- Three-point chassis design with 180° drive motor steering arc provides exceptional maneuverability
- Powerhead-mounted stability casters for additional truck stability and operator confidence at working heights of up to twenty feet

Operator Compartment

- Ergonomic fingertip control for travel, lift and lower functions
- Logical, intuitive drive characteristics while traveling at elevation or lowered
- Spacious operator compartment designed for productivity
- Large storage compartment allows storage of clip boards, pens and miscellaneous fulfillment tools
- Retractable compartment side-rails with audible alarm when raised

Regenerative Brakes

- When the operator removes their hand from travel control
- When travel speeds are reduced, electromagnetic parking brake is applied after the truck is stopped

| Model # | Mast | Lift Height | Col Height | Ext. Height | Load Tray Height | Working Height | Weight Chassis Only |
|---------|--------------|-------------|------------|-------------|------------------|----------------|---------------------|
| | | A | C | E | F | G | |
| MV05 | Triple Stage | 126 | 62.6 | 178.6 | 159.0 | 203 | 2268 |
| MV05 | Triple Stage | 162 | 82.0 | 236.0 | 195.0 | 239 | 2610 |
| MV05 | Triple Stage | 192 | 83.0 | 264.0 | 225.0 | 269 | 3160 |

Consult factory for derate. For indoor operation and level surfaces only.

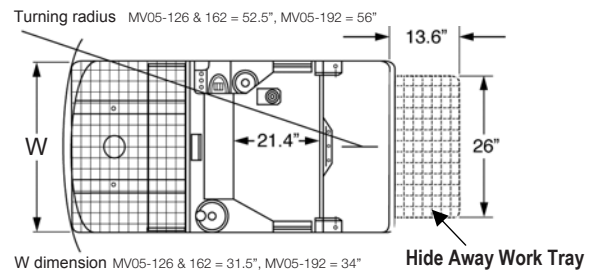
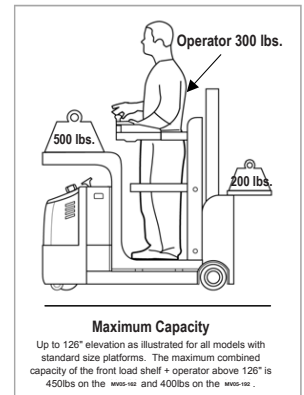
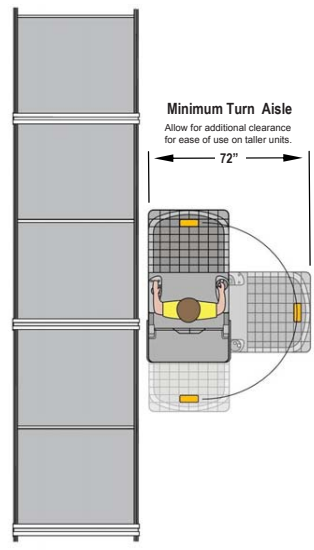
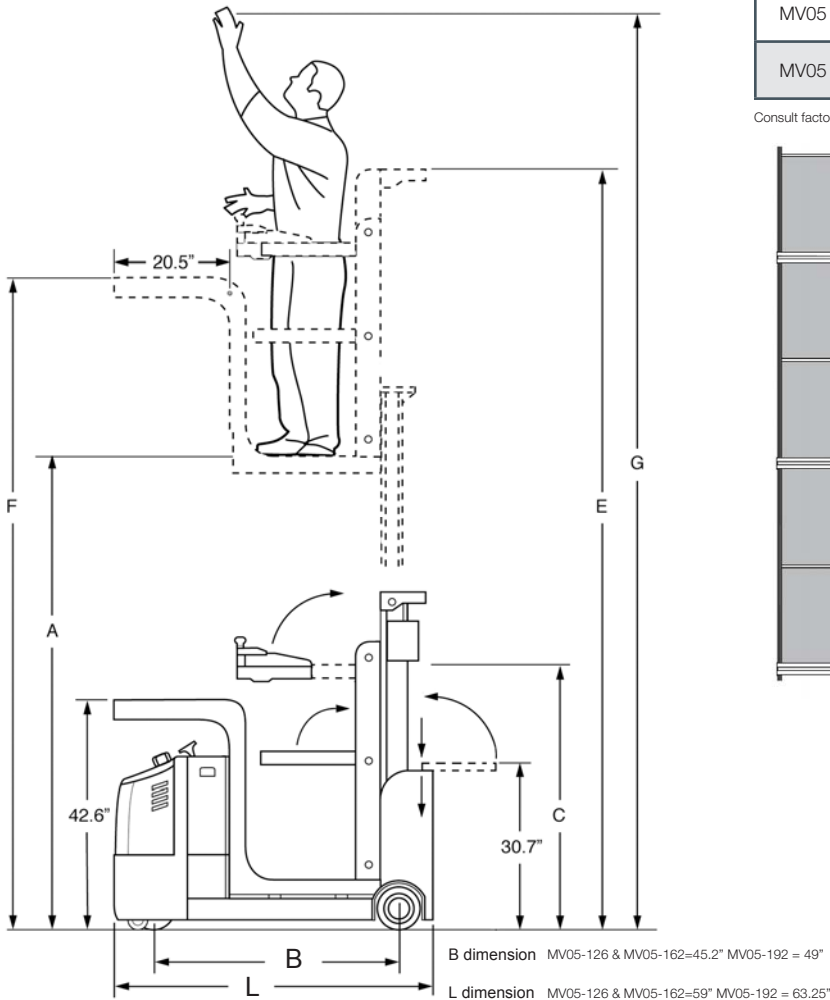

For more information on Linde material handling equipment, please contact:

KION North America Corporation
 2450 West 5th North Street, Summerville, SC 29483
 Phone: (843) 875.8000 Truck Sales Fax: (843) 875.8471
 Email: trucksales.na@kiongroup.com
 www.kion-na.com



ANSI: Standard truck meets all applicable mandatory requirements of ANSI/SQSDF B56.1 standards for powered industrial trucks. This information is provided for informational purposes only. Performance and capacity may vary due to load conditions and other factors. Always use proper operating procedures. All metrics are not direct equivalents and are for informational purposes only. KION North America Corporation reserves the right to make improvements and changes in specification or design without notice and without incurring obligation. Please check with your authorized Linde dealer for information on possible updates or revisions.

linda_spec_8906_MV05
 USA_V1_20190307